

TECHNICAL DATA SHEET

SURFACE MOUNTED FOLDING SHOWER SEAT



ACCENT SERIES 9558

- Stainless steel tubing
- White laminate seat bonded to a phenolic core

Overall Dimensions
432mm W x 406mm projection
(when in use)

CONSTRUCTION:

FRAME: Fabricated of 25mm dia. type 304 (18-8), 18 gauge stainless steel tubing. Heliarc welded.

WALL BRACKET: Fabricated of 16 gauge stainless steel with stainless steel piano hinges.

RETAINING BRACKET: Fabricated of 16 gauge stainless steel. Positive bullet-type catch holds seat securely in up or down position.

SEAT: Fabricated of 10mm thick solid plastic (white) laminate, made of coloured melamine bonded under high pressure to a phenolic core. All exposed edges are machined smooth to a uniform dark finish.

OPERATION:

Hinged seat folds up and out of the way when not in use. When properly installed, seat can support up to 250 lbs static load.

INSTALLATION:

Provide concealed backing or anchors as specified by architect before finished wall is applied. Secure to wall with mounting screws (included) at holes provided. Locate mounting holes 408mm above finished floor for comfortable adult use.

GUIDE SPECIFICATION:

Folding plastic laminate shower seat shall be fabricated of 10mm thick melamine bonded to a phenolic core secured to a stainless steel frame of 25mm diameter, 18 gauge tubing. Wall bracket of 16 gauge stainless steel with heavy duty hinges.

MODEL 9558

Options:

- 9558-24 Folding Shower Seat 600mm wide
- 9558-40 Folding Shower Seat 960mm wide

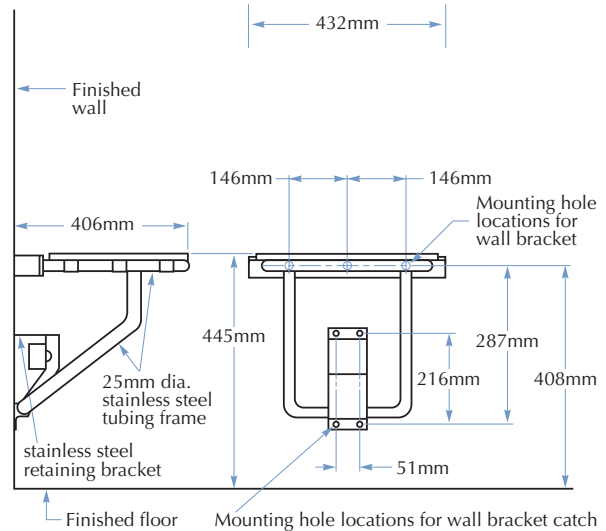
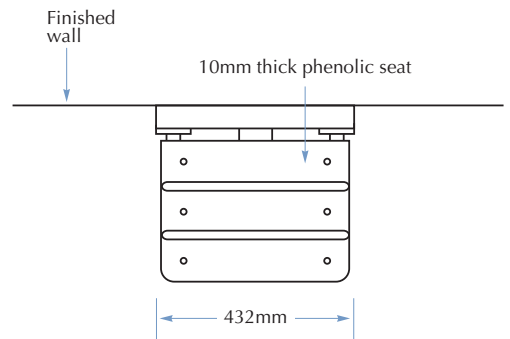

TOLL FREE 1300 364 561

The manufacturer reserves the right to make changes in design and material without formal notice and without incurring obligation.

Bradley
AUSTRALIA.COM