

SURFACE MOUNTED GRAB BAR



GRAB BAR AND RAILS 832-1426

- 32mm diameter
- Concealed fixing
- All dimensions centre to centre
- Standard - 870mm x 700mm at 45° (under slung)
- Complies with AS 1428.1
- For special sizes nominate:
Horizontal (A) =
45° Leg (B) =

CONSTRUCTION:

FLANGES: Fabricated of type 304 (18-8), 80mm dia. 13 gauge stainless steel.

ESCUTCHEONS: Fabricated of type 304 (18-8), 22 gauge stainless steel.

One-piece drawn construction with exposed surfaces in architectural satin finish. Snap over flanges to conceal mounting screws.

TUBING: Fabricated of type 304 (18-8), 32mm (1-1/4") O.D.

18 gauge stainless steel, seamless construction with exposed surfaces in architectural satin finish. Bent ends of tubing pass through the flanges and are heliarc welded into a single structural unit for maximum strength. Intermediate supports are contour cut and joined by heliarc welding to form an integral part of the grab bar. All welds ground and polished to blend. Mandrel bending process maintains uniform bar diameter.

STRENGTH:

When properly mounted, all Bradley heavy duty grab bar systems meet or exceed the requirements of Australian Standard AS1428.1(2,3), of ANSI Standard A117.1, the ADA and ABA Accessibility Guidelines for Buildings and Facilities (ADAAG) and the Uniform Federal Accessibility Standard (UFAS).

INSTALLATION:

Secure to wall where adequate in-wall backing exists. Use bar as template to locate mounting holes. Drill holes and set anchors as appropriate. Mount grab rail and secure mounting screws. Snap escutcheons into place.

GUIDE SPECIFICATION:

Grab bar shall be fabricated of type 304 satin finish stainless steel with concealed mounting flanges in sizes and configurations as indicated.

MODEL 832-1426

Options:
832-1426 Left Hand (Shown) Satin Finish
832-1427 Right Hand Satin Finish

Finish Options:
-2 Peened (Safety Grip)
-4 Mirror Polished
-6 Powdercoat

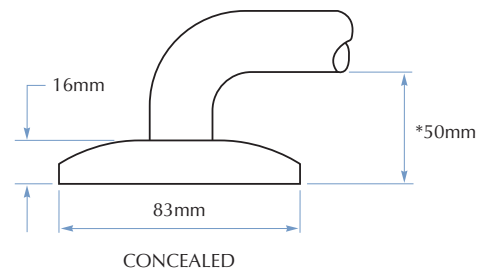
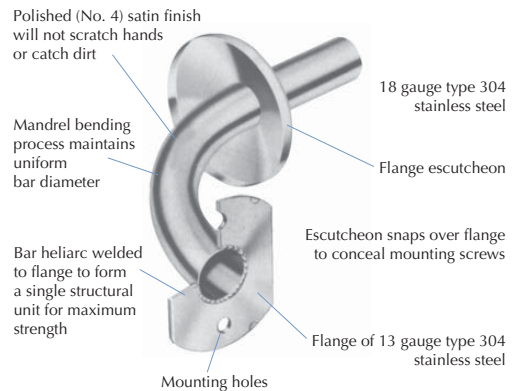
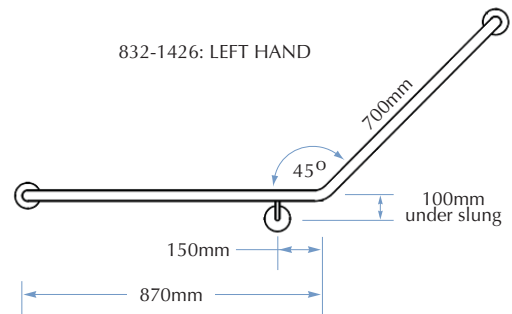

*50mm wall clearance required under most building design codes

TOLL FREE 1300 364 561

The manufacturer reserves the right to make changes in design and material without formal notice and without incurring obligation.

Bradley
AUSTRALIA.COM