

SURFACE MOUNTED DROP DOWN GRAB BAR



DROP DOWN GRAB BAR RAIL 832-101

- Satin finish stainless steel

Back Plate Dimensions

100mm W x 300mm H

- Unit Projects 800mm

MODEL 832-101

Options:

-2 Peened (Safety Grip)

-51 with Toilet Roll Holder

-NC with Nurse Call Button

CONSTRUCTION:

TUBING: Fabricated of type 304 (18-8), 32mm (1-1/4") O.D. 18 gauge stainless steel, seamless construction with exposed surfaces in architectural satin finish. Bent ends of tubing pass through the flanges and are heliarc welded into a single structural unit for maximum strength. Intermediate supports are contour cut and joined by heliarc welding to form an integral part of the grab bar. All welds ground and polished to blend. Mandrel bending process maintains uniform bar diameter.

STRENGTH:

When properly mounted, all Bradley heavy duty grab bar systems meet or exceed the requirements of Australian Standard AS1428.1(2,3), of ANSI Standard A117.1, the ADA and ABA Accessibility Guidelines for Buildings and Facilities (ADAAG) and the Uniform Federal Accessibility Standard (UFAS).

INSTALLATION:

Secure to wall where adequate in-wall backing exists. Use bar as template to locate mounting holes. Drill holes and set anchors as appropriate. Mount grab rail and secure mounting screws.

GUIDE SPECIFICATION:

Grab bar shall be fabricated of type 304 satin finish stainless steel with concealed mounting flanges in sizes and configurations as indicated.

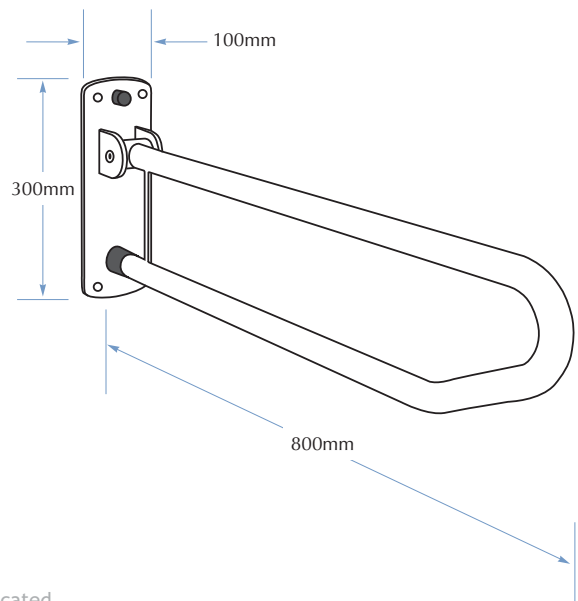

TOLL FREE 1300 364 561

The manufacturer reserves the right to make changes in design and material without formal notice and without incurring obligation.

Bradley
AUSTRALIA.COM