

SURFACE MOUNTED LIQUID SOAP DISPENSER

MODEL 6542



SOAP DISPENSER 6542

- Tank type - horizontal
- Satin finish stainless steel
- 1.2 litre capacity

Overall Dimensions
208mm W x 124mm H x 73mm D

CONSTRUCTION:

BODY: Fabricated of type 304 (18-8), 20 gauge stainless steel with exposed surfaces in architectural satin finish.

BACK: Fabricated of type 304 (18-8), 20 gauge stainless steel. Heliarc welded to the body.

WALL PLATE: Fabricated of heavy gauge stainless steel.

SOAP VALVE: Has chrome plated brass housing with ABS plastic mechanism.

CAPACITY:

1.2 litres of liquid soap. We recommend Bradley model PB609 liquid soap for optimum operation and performance.

OPERATION:

Push-in valve dispenses measured amount of liquid soaps, synthetic detergents and antiseptic solutions. Sight gauge indicates refill time. Locked filler top opens with special key provided.

INSTALLATION:

Secure separate mounting bracket to wall. Slide dispenser into place and secure locking screw through filler hole.

GUIDE SPECIFICATION:

Surface mounted liquid soap dispenser shall be fabricated of 20 gauge satin finish stainless steel. Dispenser shall have completely concealed mounting, vandal-resistant filler hole cover and sight gauge, with push-in corrosion-resistant liquid soap valve.

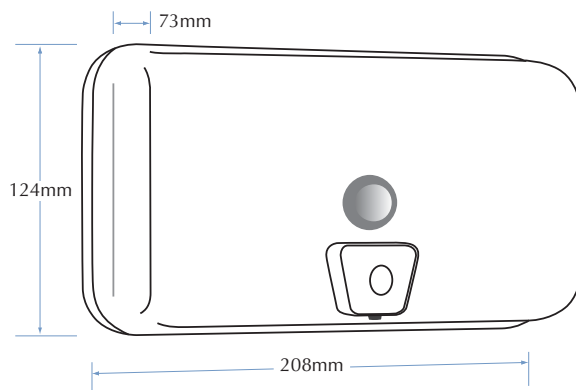

TOLL FREE 1300 364 561

The manufacturer reserves the right to make changes in design and material without formal notice and without incurring obligation.

Bradley
AUSTRALIA.COM