

RECESS MOUNTED LIQUID SOAP DISPENSER

MODEL 6437



SOAP DISPENSER 6437

- Leak proof soap container
- Satin finish stainless steel

Overall Dimensions
260mm W x 159mm H x 102mm D

CONSTRUCTION:

CABINET: Fabricated of type 304 (18-8), heavy gauge stainless steel.

FACEPLATE: Fabricated of type 304 (18-8), 18 gauge stainless steel.

Faceplate and soap vessel form one integral piece.

SOAP VESSEL LINER: Is molded high impact polystyrene.

SOAP VALVE: Of chrome plated brass with ABS mechanism.

Internal Buna-N check valves prevent leakage.

CAPACITY:

1 litre of liquid soap. We recommend Bradley model PB609 liquid soap for optimum operation and performance.

OPERATION:

Soap dispenser slides open for filling and cleaning. Push-in valve dispenses measured amounts of liquid soaps, synthetic detergents and antiseptic solutions. Sight gauge indicates refill time. Door secured with tumbler lock.

INSTALLATION:

Requires rough wall opening 216mm W x 114.5mm H x 102 D.

Secure to framing with mounting screws (included) at holes provided. Shim at screw points as required.

GUIDE SPECIFICATION:

Recessed liquid soap dispenser shall be fabricated of type 304 (18-8), heavy gauge stainless steel with exposed surfaces in satin finish. Faceplate of 18 gauge stainless 102mm steel and secured by tumbler lock.

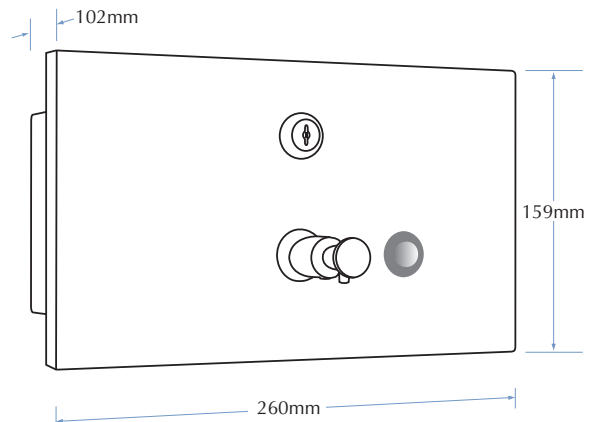

TOLL FREE 1300 364 561

The manufacturer reserves the right to make changes in design and material without formal notice and without incurring obligation.

Bradley
AUSTRALIA.COM