

SURFACE MOUNTED NAPKIN DISPOSAL UNIT

MODEL 4781-15



NAPKIN DISPOSAL 4781-15

- Satin finish stainless steel

Overall Dimensions
203mm W x 292mm H x 105mm D

CONSTRUCTION:

UNIT: Fabricated of type 304 (18-8), 22 gauge stainless steel with exposed surfaces in architectural satin finish. All welded construction with rounded front corners. Bottom equipped with lock and heavy duty stainless steel piano hinge.

COVER: Fabricated of type 304 (18-8), 22 gauge stainless steel with exposed surfaces in architectural satin finish. Heavy duty stainless steel piano hinge.

OPERATION:

Bottom opens for removal of waxed paper liner. Additional liners available from Bradley Australia.

INSTALLATION:

Secure to wall or partition with mounting screws (included) at holes provided.

GUIDE SPECIFICATION:

Surface mounted napkin disposal shall be fabricated of type 304 (18-8), 22 gauge stainless steel with exposed surfaces in satin finish. Top attached by piano hinge. Bottom hinged for easy servicing.

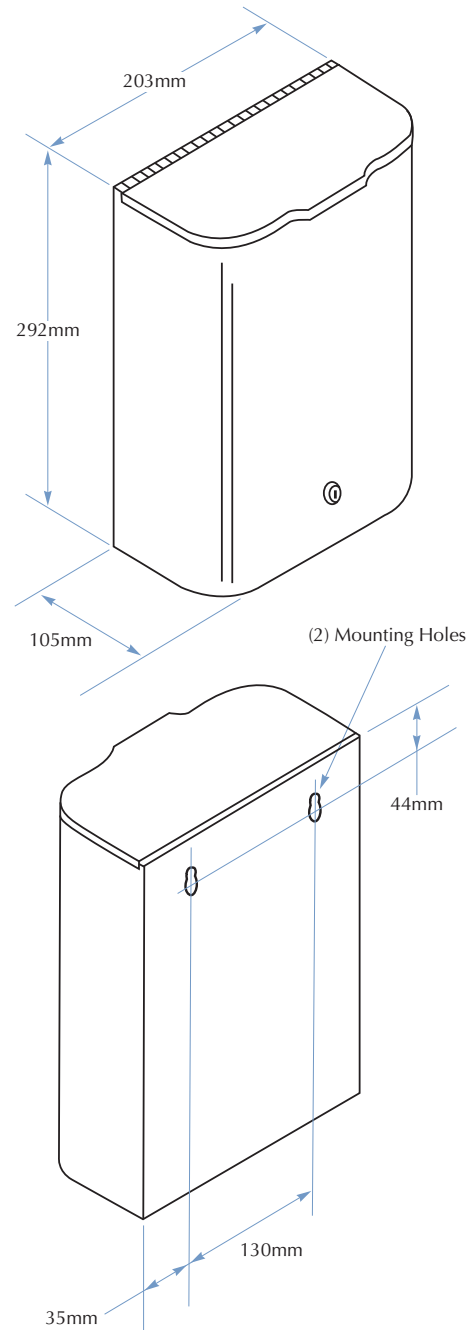

TOLL FREE 1300 364 561

The manufacturer reserves the right to make changes in design and material without formal notice and without incurring obligation.

Bradley
AUSTRALIA.COM