

## RECESSED COMBINATION UNIT



### CONTEMPORARY SERIES 2297A

- Combination 2-in-1 unit:  
Towel dispenser and waste receptacle

- Satin finish stainless steel

Overall Dimensions  
363mm W x 718mm H x 105mm D

### CONSTRUCTION:

**CABINET:** Fabricated of type 304 (18-8) 22 gauge stainless steel with exposed surfaces in architectural satin finish. Welded construction with seamless corners and burr-free edges.

**DOOR:** Fabricated of type 304 (18-8) 18 gauge stainless steel, 13mm return for maximum rigidity. Concealed full-length stainless steel piano hinge, tumbler lock keyed as other Bradley units.

**TOWEL DISPENSER:** Fabricated of type 304 (18-8) 22 gauge stainless steel. Rolled edge on dispenser opening.

**WASTE RECEPTACLE INSERT:** Fabricated of satin stainless steel.

### CAPACITY:

Towel Dispenser - holds Bradley Model 2001 paper hand towels.  
Waste Receptacle Insert - 8 litres.

### OPERATION:

Unit holds paper hand towels without the use of special adaptors.  
Waste receptacle insert removable by unlocking cabinet door.

### INSTALLATION:

Recessed unit requires Rough Wall Opening 315mm W x 670mm H x 100mm D (semi-recessed unit only 42mm deep).

Secure to framing with mounting screws at holes provided.

### GUIDE SPECIFICATION:

Recessed combination paper towel dispenser and waste receptacle shall be fabricated of heavy gauge type 304 (18-8) stainless steel with exposed surfaces in architectural satin finish. Cabinet door of 18 gauge stainless steel with full length concealed piano hinge and secured by tumbler lock.

## MODEL 2297A

Options:

2297A-10 Semi Recessed

2297A-11 Surface Mounted

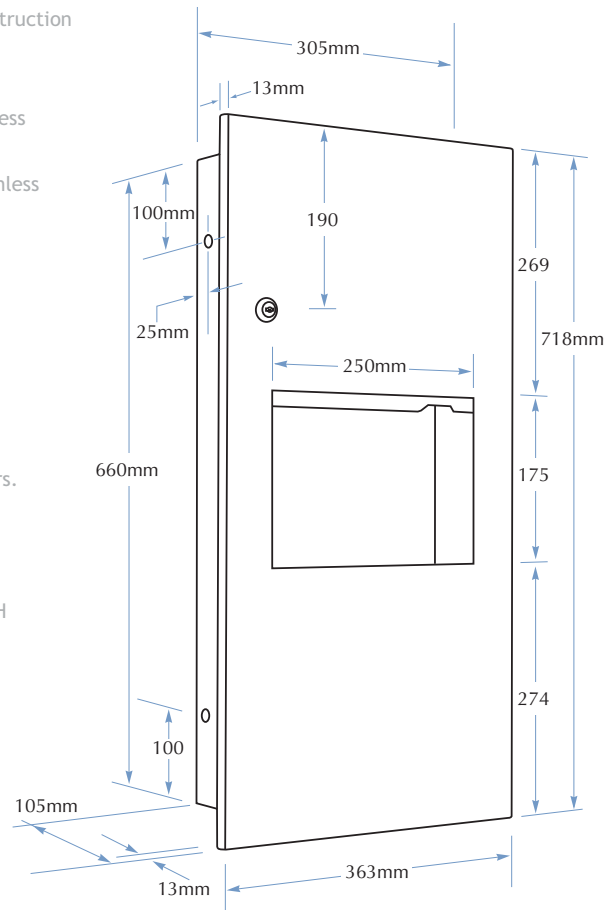

TOLL FREE 1300 364 561

The manufacturer reserves the right to make changes in design and material without formal notice and without incurring obligation.

**Bradley**  
AUSTRALIA.COM