

RECESSED MULTI-PURPOSE UNIT



MULTI-PURPOSE 2252

- Combination 2 in 1 unit:
towel dispenser/waste receptacle

- Satin finish stainless steel

Overall Dimensions
356mm W x 1422mm H x 191mm D

CONSTRUCTION:

CABINET: Fabricated of type 304 (18-8), 22 gauge stainless steel with exposed surfaces in architectural satin finish. Welded construction with seamless corners and burr-free edges.

FLANGE: Fabricated of type 304 (18-8), 22 gauge stainless steel with exposed surfaces in architectural satin finish. One piece seamless construction, 25mm wide with 7mm return.

DOORS: Fabricated of type 304 (18-8), 18 gauge stainless steel. Warp resistant, with full length piano hinge and tumbler lock keyed as other Bradley units.

TOWEL DISPENSER: Fabricated of type 304 (18-8), 22 gauge stainless steel. Rolled edge on dispenser opening.

WASTE RECEPTACLE INSERT: Fabricated of stainless steel.

CAPACITY:

Towel Dispenser - holds Bradley Model 2001 paper hand towels.

Waste Receptacle Insert - 26 litres.

OPERATION:

Unit holds paper hand towels without the use of special adaptors.

Waste receptacle insert removable by unlocking receptacle door.

INSTALLATION:

Recessed unit requires Rough Wall Opening 1385mm H x 315mm W x 190mm D. (Semi-recessed unit only 91mm deep.) Secure to framing with mounting screws (included) at holes provided. Shim at screw points as required.

GUIDE SPECIFICATION:

Recessed combination paper towel dispenser and waste receptacle shall be fabricated of type 304 (18-8), 22 gauge stainless steel with exposed surfaces in satin finish and burr-free edges. Doors of non flexing construction, equipped with heavy duty piano hinges and locks. Waste receptacle has removable 26 litre, stainless steel insert.

MODEL 2252

Options:

2252-10 Semi-Recessed

2252-11 Surface Mounted

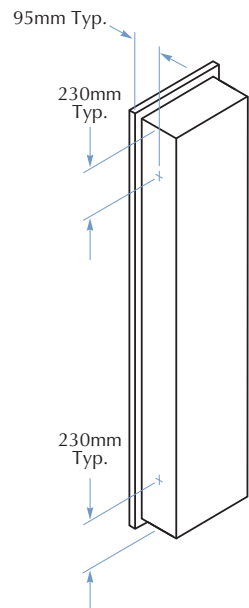
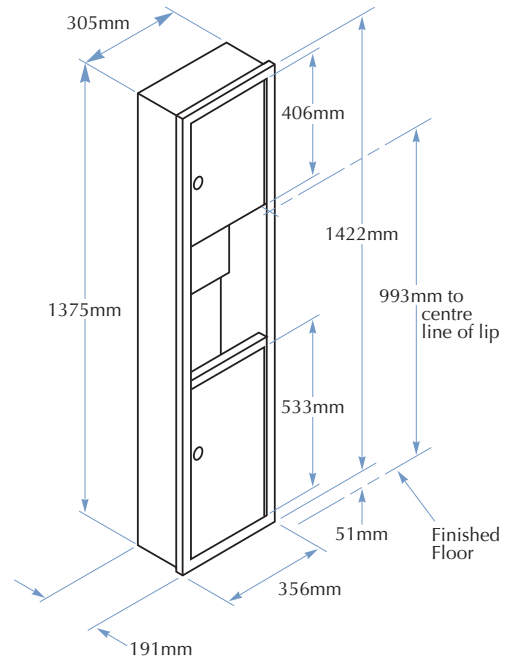

TOLL FREE 1300 364 561

The manufacturer reserves the right to make changes in design and material without formal notice and without incurring obligation.

Bradley
AUSTRALIA.COM