

## RECESSED MULTI-PURPOSE UNIT



### MULTI-PURPOSE 225

- Combination 2 in 1 unit:  
towel dispenser/waste receptacle

- Satin finish stainless steel

Overall Dimensions  
356mm W x 1890mm H x 197mm D

### CONSTRUCTION:

**CABINET:** Fabricated of type 304 (18-8), 22 gauge stainless steel with exposed surfaces in architectural satin finish. Welded construction with seamless corners and burr-free edges.

**FLANGE:** Fabricated of type 304 (18-8), 22 gauge stainless steel with exposed surfaces in architectural satin finish. One piece seamless construction, 25mm wide with 7mm return.

**DOORS:** Fabricated of type 304 (18-8), 18 gauge stainless steel. Warp resistant, with full length piano hinge and tumbler lock keyed as other Bradley units.

**TOWEL DISPENSER:** Fabricated of type 304 (18-8), 22 gauge stainless steel. Rolled edge on dispenser opening.

**WASTE RECEPTACLE INSERT:** Fabricated of stainless steel.

### CAPACITY:

Towel Dispenser - takes Bradley Model 2001 paper hand towels.

Waste Receptacle Insert - 40 litres.

### OPERATION:

Towel dispenser holds paper hand towels without use of special adaptor.

Waste receptacle insert removable by unlocking receptacle door.

### INSTALLATION:

Recessed unit requires Rough Wall Opening 1842mm H x 316mm W x 195mm D. (Semi-recessed unit only 90mm deep.) Secure to framing with mounting screws (included) at holes provided. Shim at screw points as required.

### GUIDE SPECIFICATION:

Recessed combination paper towel dispenser and waste receptacle shall be fabricated of type 304 (18-8), 22 gauge stainless steel with exposed surfaces in satin finish and burr-free edges. Doors of non flexing construction, equipped with full length piano hinges and tumbler locks. Waste receptacle has removable 40 litre, stainless steel insert.

## MODEL 225

Options:

225-10 Semi-Recessed

225-11 Surface Mounted

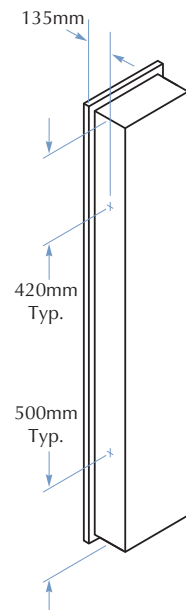
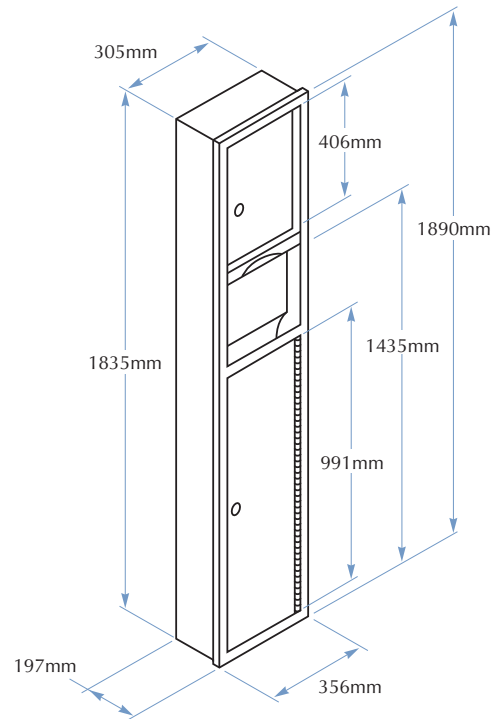

TOLL FREE 1300 364 561

The manufacturer reserves the right to make changes in design and material without formal notice and without incurring obligation.

**Bradley**  
AUSTRALIA.COM