

RECESSED COMBINATION UNIT



MULTI-PURPOSE 170

- Mirror of polished stainless steel (in architectural bright finish) and storage cabinet

- Satin finish stainless steel

Overall Dimensions
435mm W x 778mm H x 102mm D

CONSTRUCTION:

FLANGE: Fabricated of type 304 (18-8), 22 gauge stainless steel with exposed surfaces in architectural satin finish. One piece seamless construction, 25mm wide with 7mm return.

CABINET: Fabricated of type 304 (18-8), 26 gauge stainless steel.

DOOR: Fabricated of type 304 (18-8), 22 gauge stainless steel, with heavy duty full length piano hinge and tumbler lock.

MIRROR: Fabricated of type 304 (18-8), stainless steel, polished to No. 8 architectural bright finish. Very bright - excellent reflectivity, very slight polish grain.

INTERIOR SHELVES: Fabricated of type 304 (18-8), 22 gauge stainless steel. Three shelves - two adjustable, one fixed.

EXTERIOR SHELF: Fabricated of type 304 (18-8), 22 gauge stainless steel.

LOCK: On door keyed as other Bradley units.

OPERATION:

Mirror finish door conceals interior shelves.

INSTALLATION:

Recessed unit requires Rough Wall Opening 390mm W x 732mm H x 105mm D. Secure to framing with mounting screws at holes provided.

GUIDE SPECIFICATION:

Recessed multi-purpose unit, consisting of architectural bright finish stainless steel mirror and storage cabinet with three shelves, shall be fabricated of type 304 (18-8), stainless steel with exposed surfaces in satin finish. Mirror finish door with full length piano hinge and tumbler lock. Interior of storage cabinet to have three shelves - two adjustable and one fixed.

MODEL 170

Options:

170-11 Surface Mounted

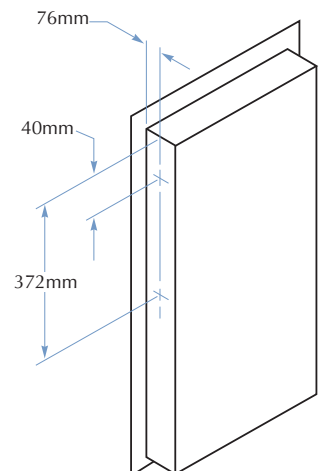
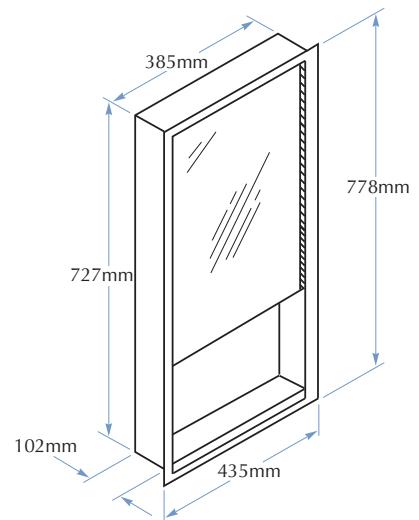

TOLL FREE 1300 364 561

The manufacturer reserves the right to make changes in design and material without formal notice and without incurring obligation.

Bradley
AUSTRALIA.COM