

## RECESSED COMBINATION UNIT



### REFLECTIONS 1297

- Towel dispenser and waste receptacle
- Ultra contemporary design in mirror finish stainless steel
- Heavy duty translucent acrylic door

Overall Dimensions:  
460mm W x 820mm H x 120mm D

## MODEL 1297

Options:  
1297-10 Semi Recessed  
1297-11 Surface Mounted

### CONSTRUCTION:

**DOOR:** Manufactured of heavy duty translucent frosted acrylic.

**FRAME:** Fabricated of type 430, 18 gauge bright annealed stainless steel. Material is stretcher levelled for uniformity. Surface is bright and smooth with mirror-like finish. Frame has 15mm return.

**CABINET:** Fabricated of type 430, 18 gauge bright annealed stainless steel. Material is stretcher levelled for uniformity. Surface is bright and smooth with mirror-like finish.

**TOWEL DISPENSER:** Fabricated of type 304, 18 gauge stainless steel with mirror polish. All welded construction.

**WASTE RECEPTACLE:** Fabricated of type 430, 18 gauge bright annealed stainless steel. Material is stretcher levelled for uniformity. Surface is bright and smooth with mirror-like finish. All welded construction. Finger hole for removal and emptying.

### CAPACITY:

Towel Dispenser - holds Bradley Model 2001 paper hand towels.  
Waste receptacle: 7 litres.

### OPERATION:

Unit holds paper hand towels without the use of special adaptors.

### INSTALLATION:

Recessed unit requires Rough Wall Opening  
374mm W x 734mm H x 115mm D  
(semi-recessed unit only 60mm deep).  
Set opening minimum 100mm from finished floor.

### GUIDE SPECIFICATION:

Recessed combination towel dispenser and waste receptacle shall be fabricated of type 430, 18 gauge bright annealed stainless steel with heavy duty translucent frosted acrylic door. Removable 7 litre bright annealed waste receptacle.

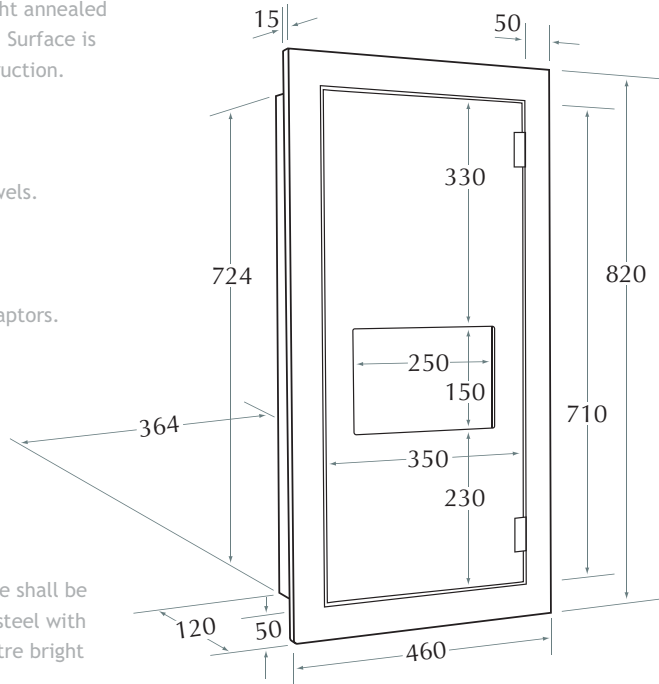

TOLL FREE 1300 364 561

The manufacturer reserves the right to make changes in design and material without formal notice and without incurring obligation.

**Bradley**  
AUSTRALIA.COM